

ON STREET ACCESSIBLE PARKING

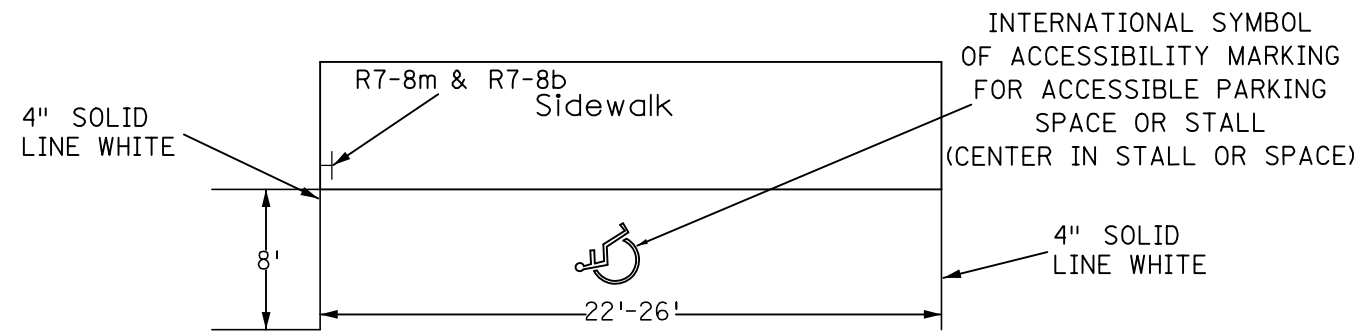

TABLE A	
TOTAL NUMBER OF PARKING SPACES OR STALLS	MINIMUM NUMBER OF ACCESSIBLE PARKING SPACES OR STALLS
1 - 25	1
26 - 50	2
51 - 75	3
76 - 100	4
101 - 150	5
151 - 200	6
201 - 300	7
301 - 400	8
401 - 500	9
501 - 1000	2 PERCENT OF TOTAL
GREATER THAN 1000	20 PLUS 1 FOR EACH 100 OR FRACTION THEREOF OVER 1000

DESIGNER'S NOTES:

- REFER TO TABLE A FOR STANDARDS ON THE MINIMUM REQUIRED NUMBER OF ACCESSIBLE PARKING SPACES OR STALLS RELATIVE TO THE TOTAL NUMBER OF PROVIDED AUTOMOBILE PARKING SPACES OR STALLS.
- IF STALL IS THE FIRST OR LAST STALL, LENGTH MAY BE REDUCED TO 20'.
- SIDEWALK ADJACENT TO HANDICAP STALL SHALL BE CLEAR OF ALL OBSTRUCTIONS.
- THERE MUST BE A SIGN POSTED SO THAT IT IS VISIBLE FROM WITHIN THE VEHICLE.
- DESIGNATED SPACES TO BE ON AN ACCESSIBLE ROUTE LOCATED AS NEAR AS POSSIBLE TO AN ACCESSIBLE ENTRANCE.
- EACH SPACE TO HAVE A SIGN WITH THE INTERNATIONAL SYMBOL OF ACCESSIBILITY, INDICATING THAT A PERMIT IS REQUIRED AND NOTIFICATION OF A \$200 MAXIMUM FINE FOR VIOLATION.



R7-8m



R7-8m



R7-8b

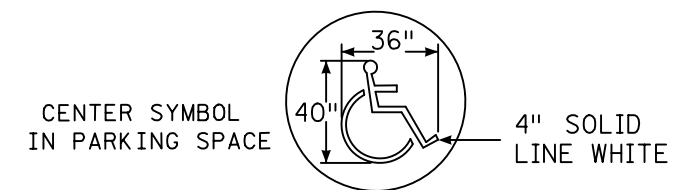

CENTER SYMBOL IN PARKING SPACE

4" SOLID LINE WHITE

TRUCK PARKING STALL

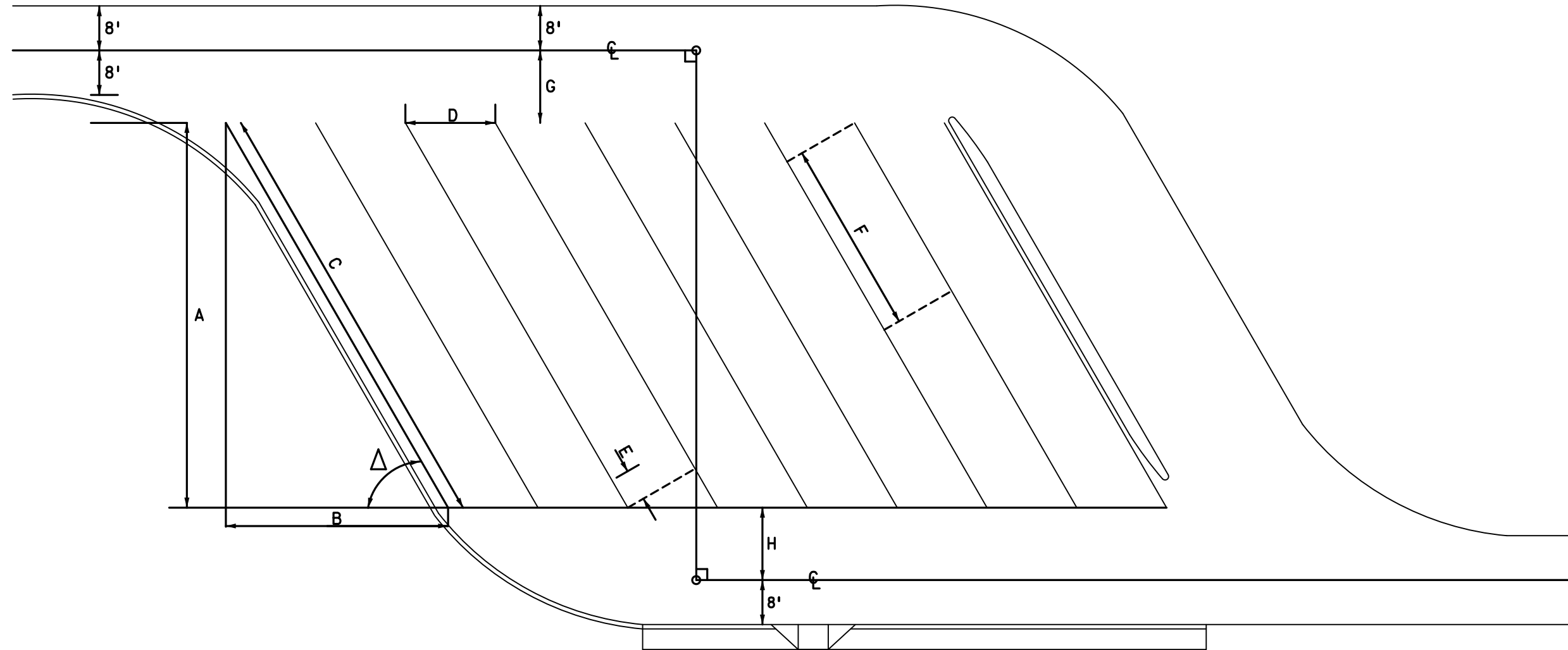

Parking Space data
(based on 14ft x 75ft minimum stall length)
(ALL DIMENSIONS ARE IN FEET OR FRACTIONS OF FEET)

Δ	A	B	C	D	E	F	G	H	$\xi-\xi$
30°	50.00	86.60	100.00	28.00	24.25	75.75	14.00	15.00	79.00
35°	55.00	78.55	95.89	24.41	20.00	75.90	19.00	18.00	92.00
40°	59.00	70.31	91.79	21.78	16.69	75.10	26.00	21.00	106.00
45°	63.00	63.00	89.10	19.80	14.00	75.10	32.00	25.00	120.00
50°	67.00	56.22	87.46	18.28	11.75	75.72	40.00	28.00	135.00
55°	70.00	49.01	85.45	17.09	9.80	75.65	46.00	31.00	147.00
60°	72.00	41.57	83.14	16.71	8.08	75.06	54.00	34.00	160.00

DESIGNER'S NOTES:

WHEN THE PARKING AREA IS LOCATED ON A CURVE, THE DIMENSIONS FOR THE PARKING SPACES SHOULD BE ADJUSTED (FANNED) TO COMPENSATE FOR CURVATURE. AN ISLAND UP TO 14FT WIDE MAY BE INCLUDED BETWEEN EVERY TEN STALLS IN THE PARKING AREA. THE LOCATION OF THE PEDESTRIAN CURB RAMP FOR THE ACCESSIBLE WILL DEPEND ON THE SITE DEVELOPMENT AND LANDING LOCATION. THE NEED FOR 150FT PARKING STALLS SHOULD BE STUDIED ON A CASE BY CASE BASIS AND ADDITIONAL PARKING PROVIDED FOR AS MANY AS REQUIRED.

ACCESSIBLE PARKING FOR PARKING LOTS

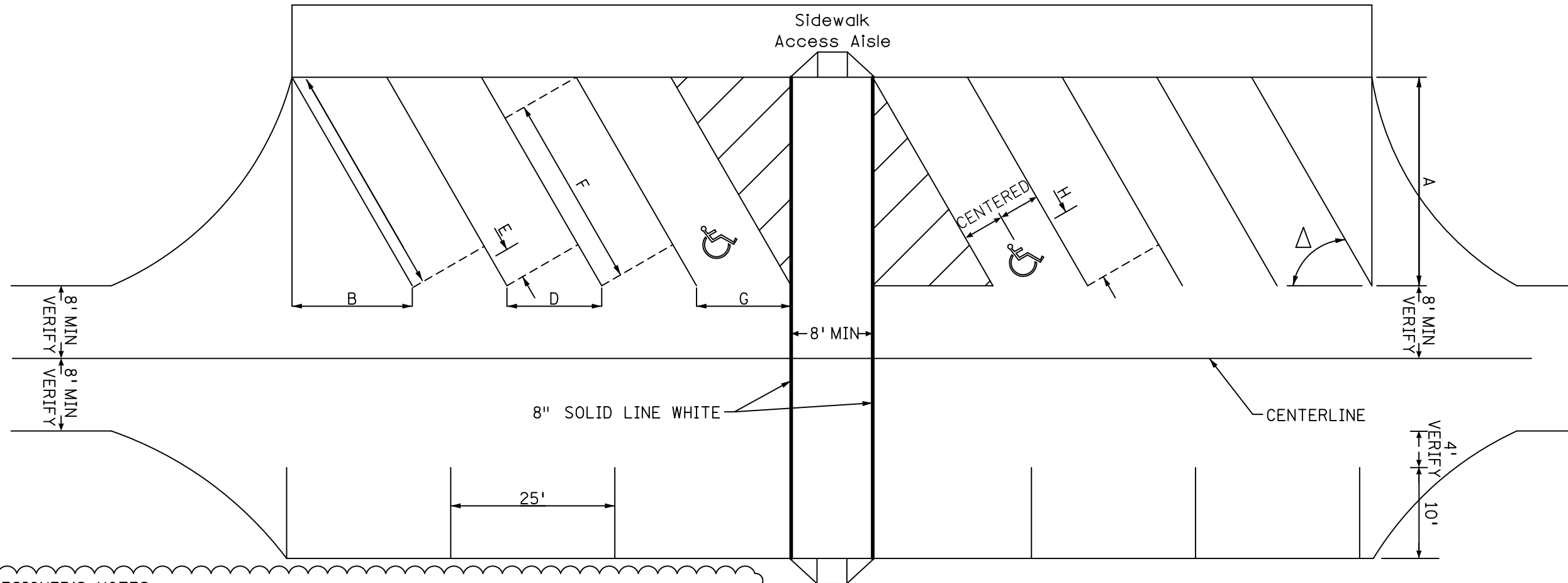

DESIGNER'S NOTES:

REFER TO TABLE A FOR STANDARDS ON THE MINIMUM REQUIRED NUMBER OF ACCESSIBLE PARKING SPACES OR STALLS RELATIVE TO THE TOTAL NUMBER OF PROVIDED AUTOMOBILE PARKING SPACES OR STALLS.

- ONE IN EVERY EIGHT ACCESSIBLE SPACES, BUT NOT LESS THAN ONE, SHALL BE SERVED BY AN ACCESS AISLE 96 IN WIDE AND SHALL BE DESIGNATED "VAN ACCESSIBLE."
- THERE MUST BE A SIGN POSTED SO THAT IT IS VISIBLE FROM WITHIN THE VEHICLE.
- EACH DESIGNATED SPACE MUST BE 8' WIDE WITH AN ADJACENT 5' WIDE ACCESS AISLE.
- VAN ACCESSIBLE SPACE MUST HAVE AN ADJACENT 8' WIDE ACCESS AISLE.
- VAN ACCESSIBLE SPACE MUST HAVE A SIGN INDICATING "VAN ACCESSIBLE"
- DESIGNATED SPACES TO BE ON AN ACCESSIBLE ROUTE LOCATED AS NEAR AS POSSIBLE TO AN ACCESSIBLE ENTRANCE.
- EACH SPACE TO HAVE A SIGN WITH THE INTERNATIONAL SYMBOL OF ACCESSIBILITY, INDICATING THAT A PERMIT IS REQUIRED AND NOTIFICATION OF A \$200 MAXIMUM FINE FOR VIOLATION.
- TWO ACCESSIBLE PARKING SPACES MAY SHARE A COMMON ACCESS AISLE.



PARKING
VEHICLE ID
REQUIRED
UP TO \$200 FINE
FOR VIOLATION

R7-8m

VAN
ACCESSIBLE

R7-8b



PARKING
VEHICLE ID
REQUIRED
UP TO \$200 FINE
FOR VIOLATION

R7-8m

Δ	PARKING SPACE (BASED ON 18 FT. MINIMUM STALL LENGTH) (ALL DIMENSIONS ARE IN FEET OR FRACTIONS OF FEET)												
	ALL STALLS						10' WIDE STALLS						
	A	B	C	D	E	F	G	H	D	E	F	G	H
45°	22.00	22.00	31.11	-	-	-	-	-	16.97	12.00	19.11	16.97	12.00
	20.00	20.00	28.28	14.14	10.00	18.28	14.14	10.00	-	-	-	-	-
50°	22.00	18.46	28.72	-	-	-	-	-	15.66	10.07	18.65	15.67	10.07
	21.00	17.62	28.41	13.05	8.39	19.02	13.05	8.39	-	-	-	-	-
55°	22.00	15.40	26.86	-	-	-	-	-	14.65	8.40	18.64	14.65	8.40
	21.00	14.70	25.64	12.21	7.00	18.64	12.21	7.00	-	-	-	-	-
60°	22.00	12.70	25.40	-	-	-	-	-	13.86	6.93	18.48	13.86	6.93
	21.00	12.12	24.25	11.55	5.77	18.48	11.55	5.77	-	-	-	-	-

INTERNATIONAL SYMBOL
OF ACCESSIBILITY MARKING
FOR ACCESSIBLE PARKING
SPACE OR STALL

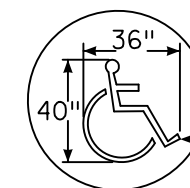

4" SOLID
LINE WHITE

**TYPICAL MARKINGS FOR
ACCESS AISLE**

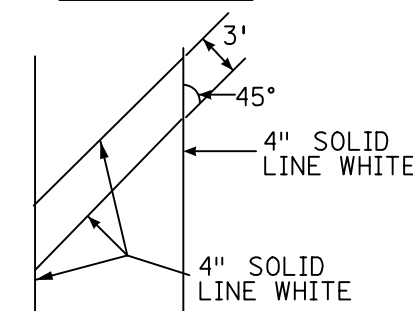

ACCESSIBLE PARKING FOR PARKING LOTS

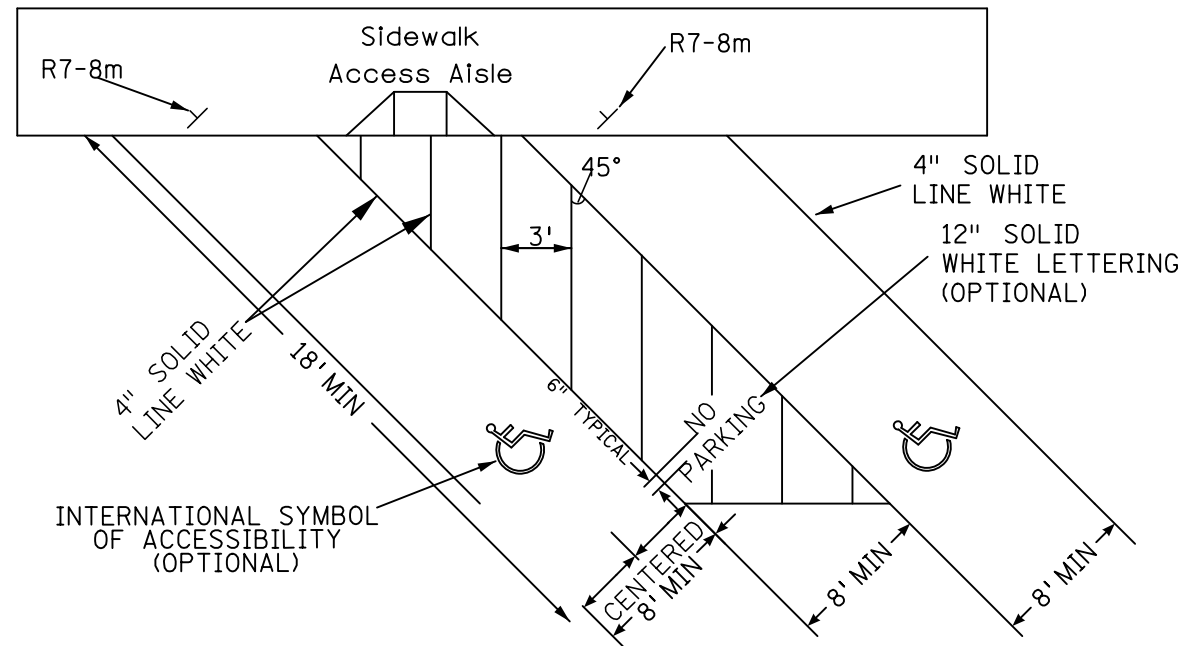

TOTAL NUMBER OF MARKED OR METERED PARKING SPACES ON THE BLOCK PERIMETER	MINIMUM NUMBER OF ACCESSIBLE PARKING SPACES
1 - 25	1
26 - 50	2
51 - 75	3
76 - 100	4
101 - 150	5
151 - 200	6
201 and over	4% of total

TYPICAL MARKINGS FOR ACCESS AISLE

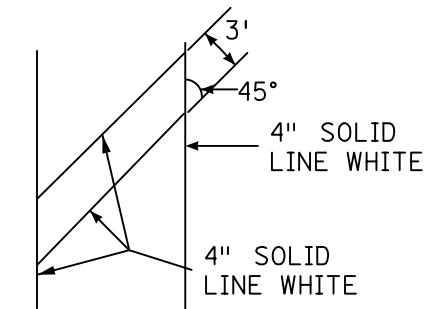

DESIGNER'S NOTES:

- REFER TO TABLE A FOR STANDARDS ON THE MINIMUM REQUIRED NUMBER OF ACCESSIBLE PARKING SPACES OR STALLS RELATIVE TO THE TOTAL NUMBER OF PROVIDED AUTOMOBILE PARKING SPACES OR STALLS.
- ONE IN EVERY EIGHT ACCESSIBLE SPACES, BUT NOT LESS THAN ONE, SHALL BE SERVED BY AN ACCESS AISLE 96 IN WIDE AND SHALL BE DESIGNATED "VAN ACCESSIBLE."
- THERE MUST BE A SIGN POSTED SO THAT IT IS VISIBLE FROM WITHIN THE VEHICLE.
- EACH DESIGNATED SPACE MUST BE 8' WIDE WITH AN ADJACENT 5' WIDE ACCESS AISLE.
- VAN ACCESSIBLE SPACE MUST HAVE AN ADJACENT 8' WIDE ACCESS AISLE.
- VAN ACCESSIBLE SPACE MUST HAVE A SIGN INDICATING "VAN ACCESSIBLE"
- DESIGNATED SPACES TO BE ON AN ACCESSIBLE ROUTE LOCATED AS NEAR AS POSSIBLE TO AN ACCESSIBLE ENTRANCE.
- EACH SPACE TO HAVE A SIGN WITH THE INTERNATIONAL SYMBOL OF ACCESSIBILITY, INDICATING THAT A PERMIT IS REQUIRED AND NOTIFICATION OF A \$200 MAXIMUM FINE FOR VIOLATION.
- TWO ACCESSIBLE PARKING SPACES MAY SHARE A COMMON ACCESS AISLE.



R7-8m



R7-8m



R7-8b

INTERNATIONAL SYMBOL OF ACCESSIBILITY MARKING FOR ACCESSIBLE PARKING SPACE OR STALL

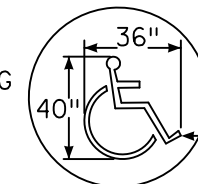

4" SOLID LINE WHITE

ACCESSIBLE PARKING FOR PARKING LOTS

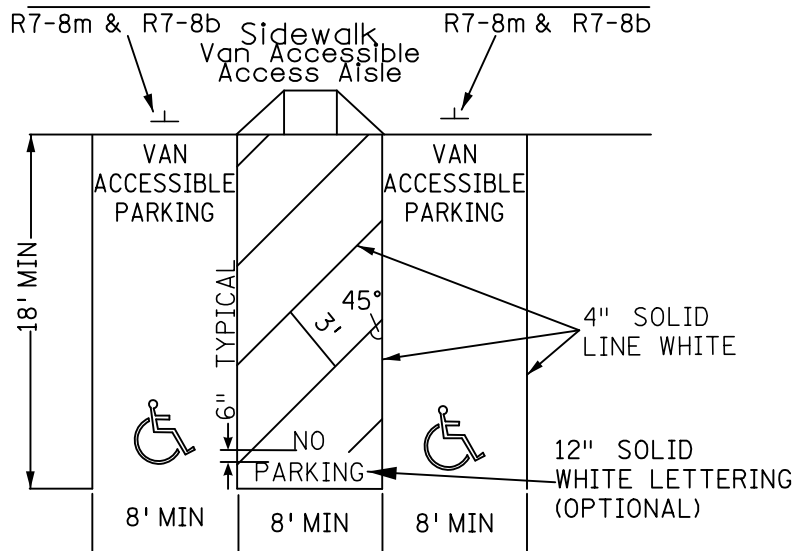
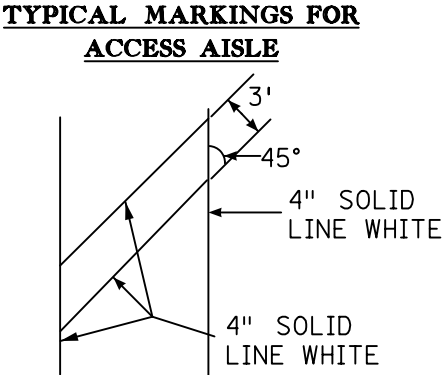
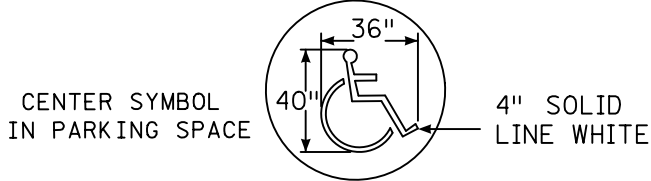
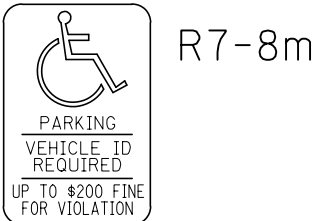
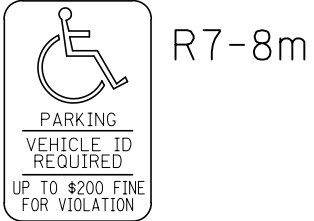

TABLE A	
TOTAL NUMBER OF MARKED OR METERED PARKING SPACES ON THE BLOCK PERIMETER	MINIMUM NUMBER OF ACCESSIBLE PARKING SPACES
1 - 25	1
26 - 50	2
51 - 75	3
76 - 100	4
101 - 150	5
151 - 200	6
201 and over	4% of total



- DESIGNER'S NOTES:**
- REFER TO TABLE A FOR STANDARDS ON THE MINIMUM REQUIRED NUMBER OF ACCESSIBLE PARKING SPACES OR STALLS RELATIVE TO THE TOTAL NUMBER OF PROVIDED AUTOMOBILE PARKING SPACES OR STALLS.
 - ONE IN EVERY EIGHT ACCESSIBLE SPACES, BUT NOT LESS THAN ONE, SHALL BE SERVED BY AN ACCESS AISLE 96 IN WIDE AND SHALL BE DESIGNATED "VAN ACCESSIBLE."
 - THERE MUST BE A SIGN POSTED SO THAT IT IS VISIBLE FROM WITHIN THE VEHICLE.
 - EACH DESIGNATED SPACE MUST BE 8' WIDE WITH AN ADJACENT 5' WIDE ACCESS AISLE.
 - VAN ACCESSIBLE SPACE MUST HAVE AN ADJACENT 8' WIDE ACCESS AISLE.
 - VAN ACCESSIBLE SPACE MUST HAVE A SIGN INDICATING "VAN ACCESSIBLE"
 - DESIGNATED SPACES TO BE ON AN ACCESSIBLE ROUTE LOCATED AS NEAR AS POSSIBLE TO AN ACCESSIBLE ENTRANCE.
 - EACH SPACE TO HAVE A SIGN WITH THE INTERNATIONAL SYMBOL OF ACCESSIBILITY, INDICATING THAT A PERMIT IS REQUIRED AND NOTIFICATION OF A \$200 MAXIMUM FINE FOR VIOLATION.
 - TWO ACCESSIBLE PARKING SPACES MAY SHARE A COMMON ACCESS AISLE.



ACCESSIBLE PARKING FOR PARKING LOTS

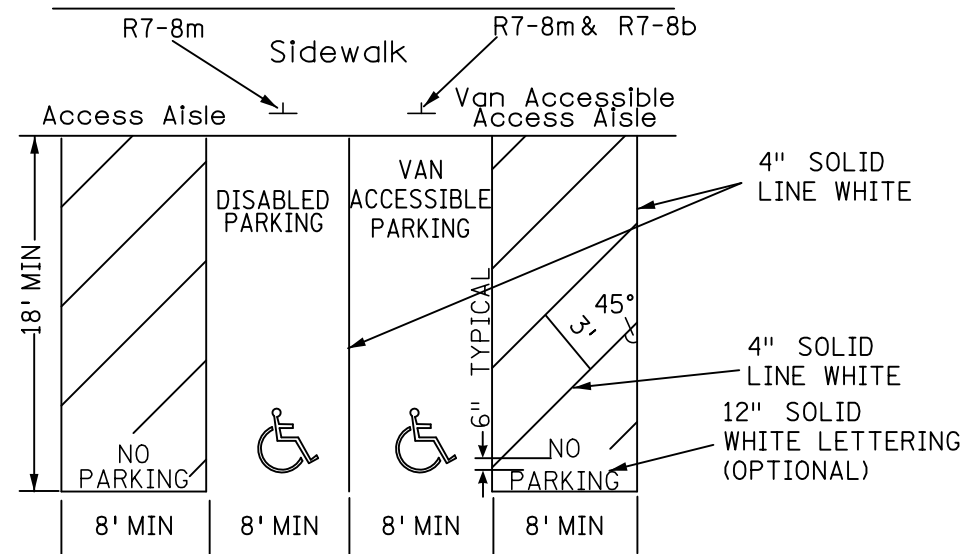

TOTAL NUMBER OF MARKED OR METERED PARKING SPACES ON THE BLOCK PERIMETER	MINIMUM NUMBER OF ACCESSIBLE PARKING SPACES
1 - 25	1
26 - 50	2
51 - 75	3
76 - 100	4
101 - 150	5
151 - 200	6
201 and over	4% of total

TYPICAL MARKINGS FOR ACCESS AISLE

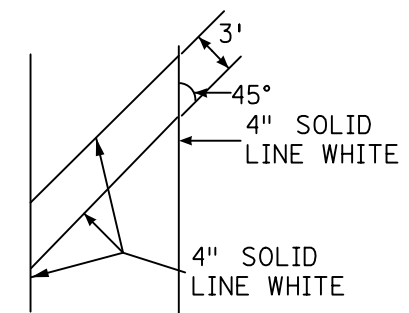

DESIGNER'S NOTES:

- REFER TO TABLE A FOR STANDARDS ON THE MINIMUM REQUIRED NUMBER OF ACCESSIBLE PARKING SPACES OR STALLS RELATIVE TO THE TOTAL NUMBER OF PROVIDED AUTOMOBILE PARKING SPACES OR STALLS.
- ONE IN EVERY EIGHT ACCESSIBLE SPACES, BUT NOT LESS THAN ONE, SHALL BE SERVED BY AN ACCESS AISLE 96 IN WIDE AND SHALL BE DESIGNATED "VAN ACCESSIBLE."
- THERE MUST BE A SIGN POSTED SO THAT IT IS VISIBLE FROM WITHIN THE VEHICLE.
- EACH DESIGNATED SPACE MUST BE 8' WIDE WITH AN ADJACENT 5' WIDE ACCESS AISLE.
- VAN ACCESSIBLE SPACE MUST HAVE AN ADJACENT 8' WIDE ACCESS AISLE.
- VAN ACCESSIBLE SPACE MUST HAVE A SIGN INDICATING "VAN ACCESSIBLE"
- DESIGNATED SPACES TO BE ON AN ACCESSIBLE ROUTE LOCATED AS NEAR AS POSSIBLE TO AN ACCESSIBLE ENTRANCE.
- EACH SPACE TO HAVE A SIGN WITH THE INTERNATIONAL SYMBOL OF ACCESSIBILITY, INDICATING THAT A PERMIT IS REQUIRED AND NOTIFICATION OF A \$200 MAXIMUM FINE FOR VIOLATION.
- TWO ACCESSIBLE PARKING SPACES MAY SHARE A COMMON ACCESS AISLE.



R7-8m



R7-8m



R7-8b

