

STANDARD SIGN TABULATION

DISTRICT #: Metro
 IPLOT NAME: APR - TPAR Sample Plan 3 for reference only
 PATH & FILENAME: OTST\Work\Zone\Templates\2020\new 20191230 APARVAPR-TPAR Sample Plan 20210602\APR - TPAR Sample Plan 20210602\APR - TPAR Sample Plan 20210602.dwg

"M" SERIES			
SIGN	SIGN NO.	COLOR	SIZE (IN. X IN.)
	M1-5a	WHITE AND GOLD ON BLUE	36" X 36"
	M5-1	WHITE ON BLUE	30" X 24"
	M6-1	WHITE ON BLUE	30" X 24"
	M6-3	WHITE ON BLUE	30" X 24"
	M3-1ma	WHITE ON BLUE	36" X 18"
	M3-3ma	WHITE ON BLUE	36" X 18"
	M4-8	BLACK ON ORANGE	36" X 18"
	M4-8a	BLACK ON ORANGE	24" X 18"
	M4-9	BLACK ON ORANGE	30" X 24"
	M4-9	BLACK ON ORANGE	30" X 24"
	M4-9	BLACK ON ORANGE	30" X 24"
	M4-9mb	BLACK ON ORANGE	18" X 24"
	M4-9mb	BLACK ON ORANGE	18" X 24"

"R" SERIES			
SIGN	SIGN NO.	COLOR	SIZE (IN. X IN.)
	R3-1 R3-2	BLACK AND RED ON WHITE	36" X 36"
	R9-9	BLACK ON WHITE	30" X 18"
	R11-2	BLACK ON WHITE	48" X 30"
	R5-1	RED on WHITE	CR-ML, E, 0 36" X 36"

"G" SERIES			
SIGN	SIGN NO.	COLOR	SIZE (IN. X IN.)
	G20-2A	BLACK ON ORANGE	48" X 24"
	G20-X9	BLACK ON ORANGE	30" X 36"

"W" SERIES			
SIGN	SIGN NO.	COLOR	SIZE (IN. X IN.)
	W20-1	BLACK ON ORANGE	48" X 48"
	W21-X5R	BLACK ON ORANGE	48" X 48"
	W20-X18	BLACK ON ORANGE	48" X 48"
	W21-X5	BLACK ON ORANGE	48" X 48"
	W20-3	BLACK ON ORANGE	48" X 48"
	W20-2	BLACK ON ORANGE	48" X 48"
	W16-8P	BLACK ON ORANGE	VARIES X 8"
	W20-100P	BLACK ON ORANGE	24" X 18"
	W20-X3 L/R	BLACK ON ORANGE	48" X 48"

GENERAL NOTE :
ALL SIGN DIMENSIONS ARE IN INCHES

TRAFFIC CONTROL TABULATION SHEET

DRAWN BY: BT

CHECKED BY: SNM

CERTIFIED BY _____ LIC. NO. _____ DATE \$ DATE \$

STATE PROJ. NO. _____

SHEET NO. TC2 OF TC13 SHEETS

DISTRICT #: Metro
 PLOT NAME: APR - TPAR Sample Plan 3 for reference only
 PATH & FILENAME: OTST\WorkZone\Templates\2020\new 2019\230 APAR\APR-TPAR Sample Plan 2021\0602\APR - TPAR Sample Plan 3 for reference only.dwg

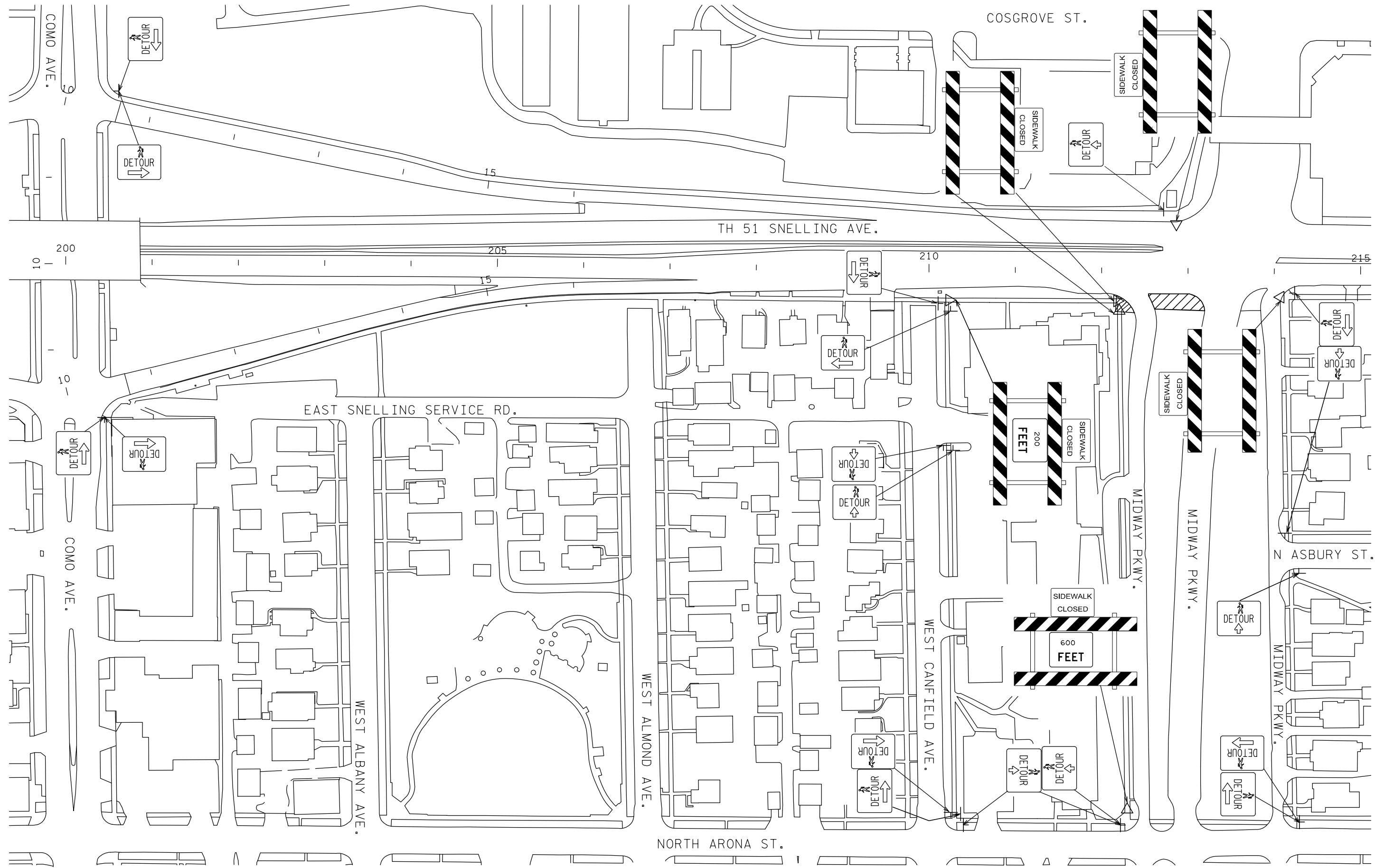

ALTERNATE PEDESTRIAN ROUTE

LICENSED PROFESSIONAL ENGINEER

DISTRICT #: Metro
 IPLOT NAME: APR - TPAR Sample Plan 3 for reference only
 PATH & FILENAME: OTST\WorkZone\Templates\2020\new 2019\230 APAR\APR-TPAR Sample Plan 20210602\APR - TPAR Sample Plan 20210602\APR-TPAR Sample Plan 20210602.dwg

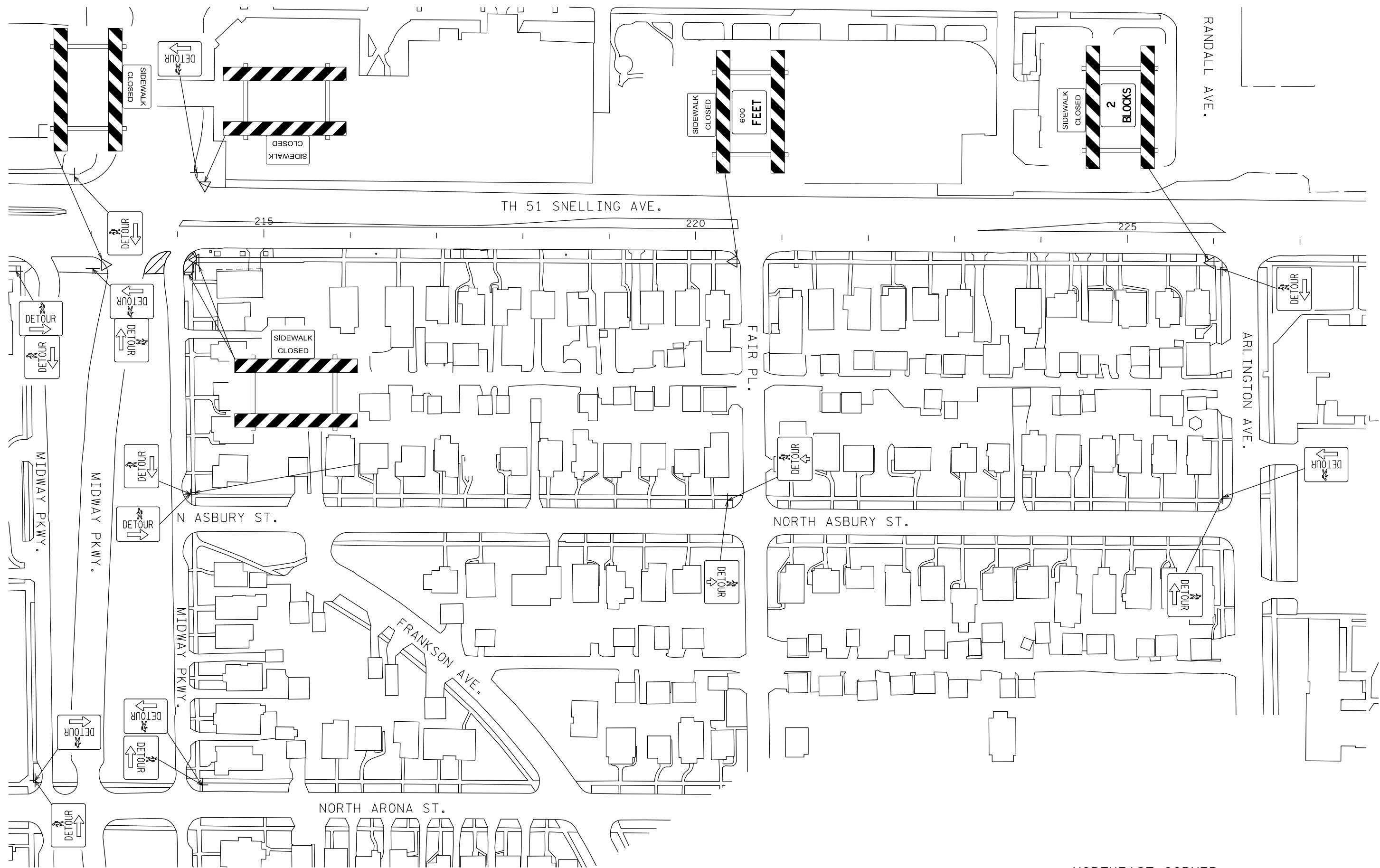

NORTHEAST CORNER

ALTERNATE PEDESTRIAN ROUTE

DRAWN BY: BT

CHECKED BY:

CERTIFIED BY _____

LICENSED PROFESSIONAL ENGINEER

LIC. NO. _____

DATE _____

DATE

STATE PROJ. NO. _____

SHEET NO. TC4

OF TC13 SHEETS

DISTRICT #: Metro
 IPLOT NAME: APR - TPAR Sample Plan 3 for reference only
 PATH & FILENAME: OTST\WorkZone\Templates\2020\new 2019\230 APAR\APR-TPAR Sample Plan 20210602\APR - TPAR Sample Plan 20210602\APR - TPAR Sample Plan 20210602.dwg

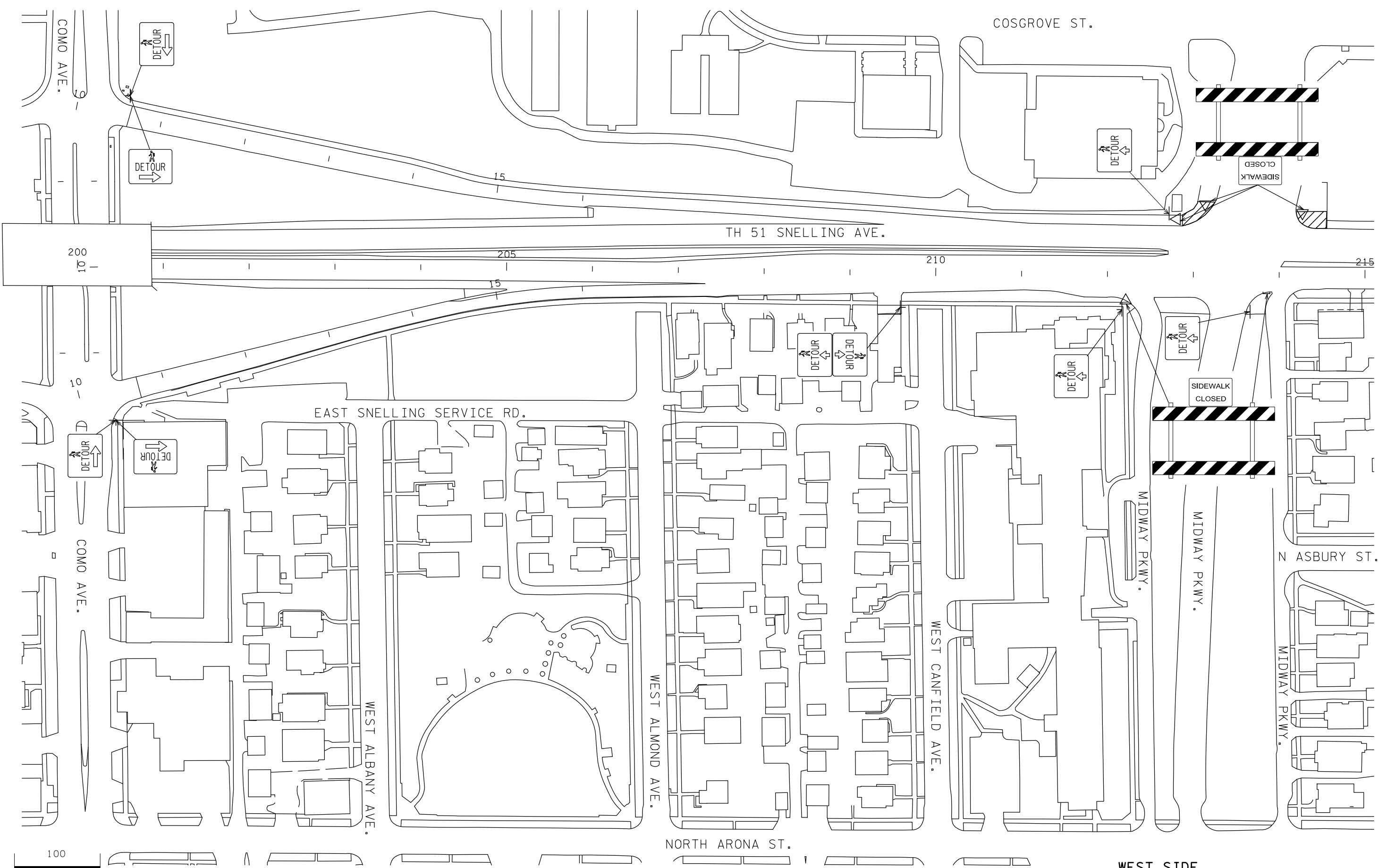

100
 SCALE IN FEET

WEST SIDE

ALTERNATE PEDESTRIAN ROUTE

DISTRICT #: Metro
 PLOT NAME: APR - TPAR Sample Plan 3 for reference only
 PATH & FILENAME: OTST\WorkZone\Templates\2020\new 20191230 APAR\APR-TPAR Sample Plan 20210602\APR - TPAR Sample Plan 3 for reference only.dgn
 PLOTTED/REVISED: 4-NOV-2021

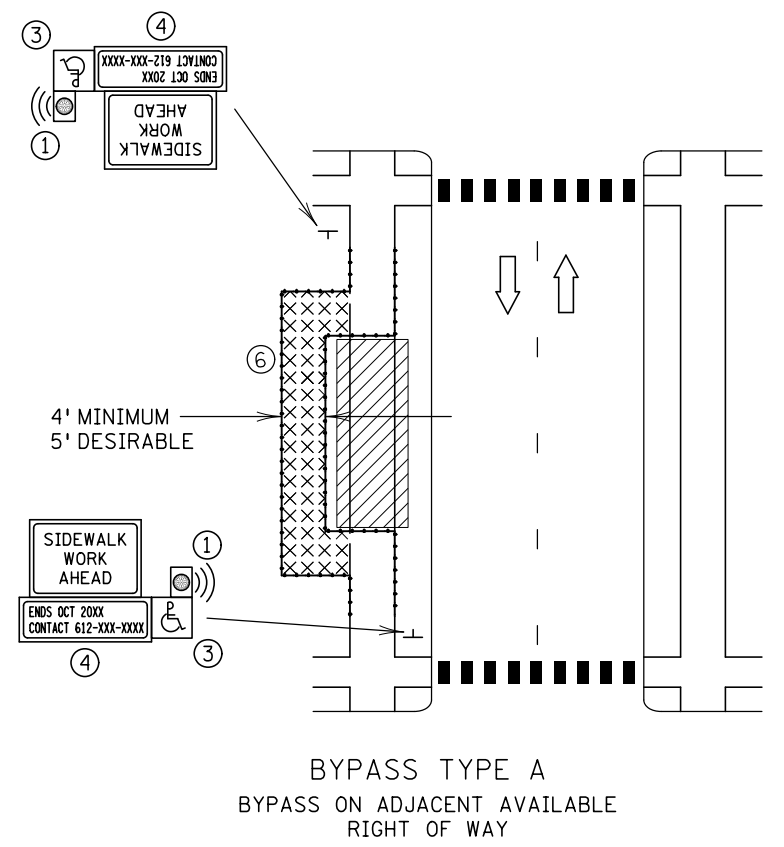

BYPASS TYPE A
 BYPASS ON ADJACENT AVAILABLE
 RIGHT OF WAY

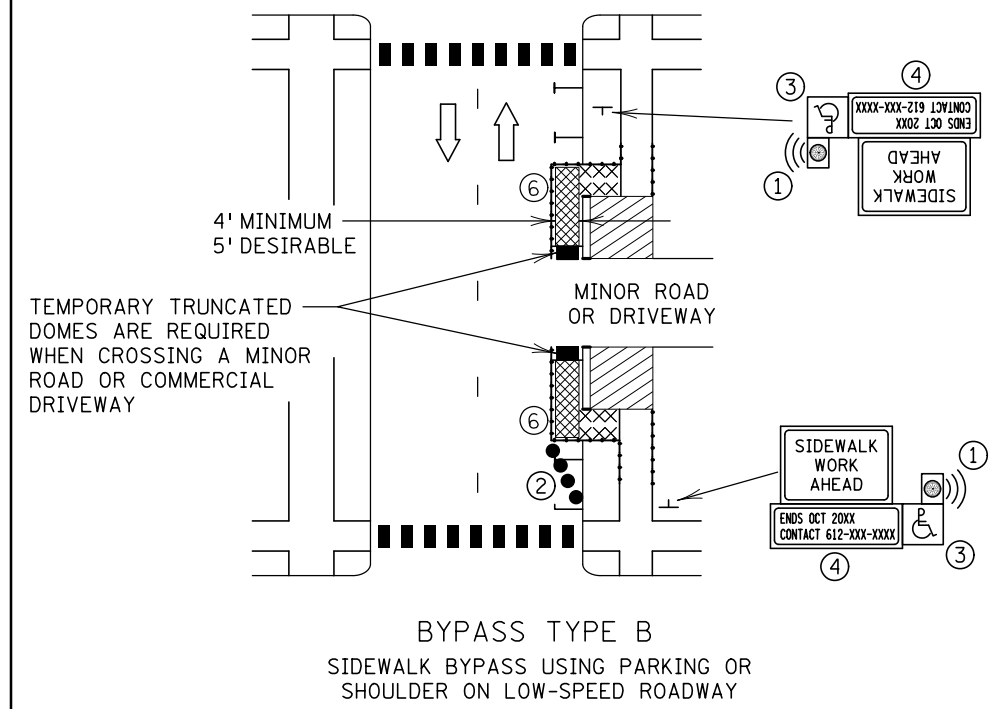

BYPASS TYPE B
 SIDEWALK BYPASS USING PARKING OR
 SHOULDER ON LOW-SPEED ROADWAY

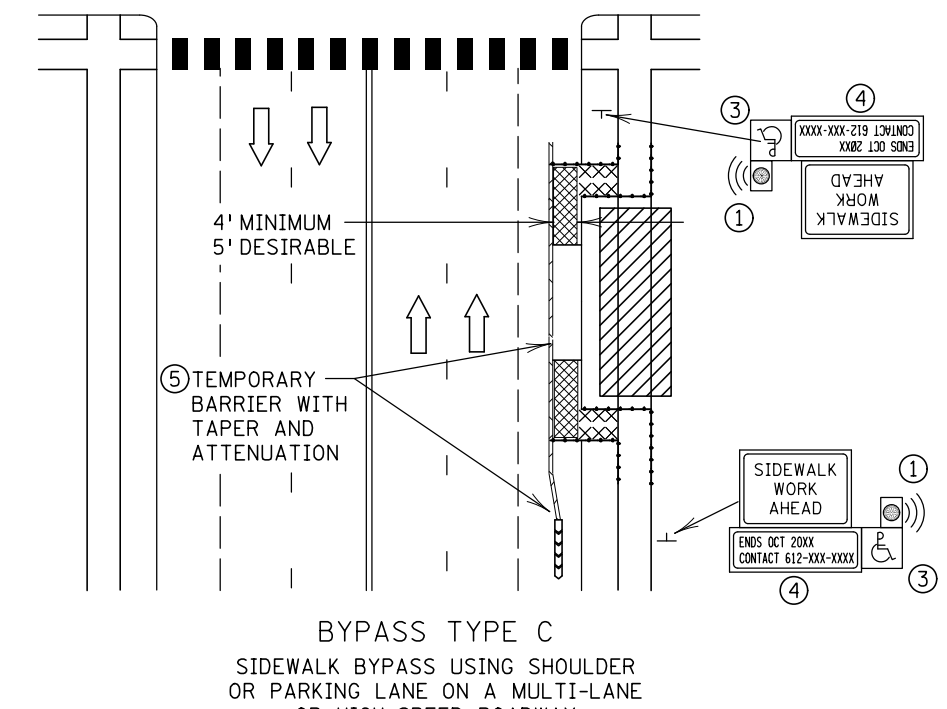

BYPASS TYPE C
 SIDEWALK BYPASS USING SHOULDER
 OR PARKING LANE ON A MULTI-LANE
 OR HIGH-SPEED ROADWAY

NOTES:

WHEN CLOSING OR RELOCATING CROSSWALKS OR SIDEWALKS, PROVIDE DETECTABLE TEMPORARY FACILITIES AND INCLUDE ACCESSIBILITY FEATURES CONSISTENT WITH EXISTING PEDESTRIAN FACILITIES. THE ALTERNATE PEDESTRIAN ROUTE (APR) MUST REMAIN OPEN AT ALL TIMES.

TEMPORARY TRAFFIC CONTROL DEVICES FOR PEDESTRIANS ARE SHOWN. OTHER DEVICES MAY BE NECESSARY TO CONTROL VEHICULAR TRAFFIC. STAGE WORK AS NECESSARY TO PROVIDE AN APR AT ALL TIMES FOR ROADWAYS WITH NO AVAILABLE DETOURS. PROVIDE A SMOOTH, CONTINUOUS, HARD SURFACE THROUGH THE LENGTH OF THE APR.

PROVIDE A FIRM, STABLE, FREE-DRAINING, NON-SLIP, TEMPORARY WALKWAY SURFACE REGARDLESS OF WEATHER CONDITIONS. SUPPORT THE TEMPORARY WALKWAY SURFACE WITH A SOLID BASE TO COVER SHORT SEGMENTS OF ROUGH, SOFT, OR UNEVEN GROUND. THE TEMPORARY WALKWAY SURFACE WILL ALLOW NORMAL USAGE OF WHEELCHAIRS, WALKERS, STROLLERS, AND OTHER MOBILITY DEVICES. CONCRETE, BITUMINOUS, STEEL, RUBBER, WOOD (3/4" OR THICKER), AND PLASTIC ARE ACCEPTABLE SURFACE MATERIALS FOR THE TEMPORARY WALKWAY SURFACE. GRAVEL, MILLINGS, AND OTHER UNEVEN SURFACES ARE NOT ACCEPTABLE SURFACE MATERIALS. IF NEEDED, PROVIDE SOIL STABILIZATION TO PREVENT EROSION AROUND TEMPORARY SURFACES. IF NEEDED, PROVIDE SOIL STABILIZATION TO PREVENT EROSION AROUND TEMPORARY SURFACES.

IF A 60" PEDESTRIAN WALKWAY WIDTH ISN'T PROVIDED FOR THE ROUTE, THEN A 60" BY 60" PASSING SPACE IS REQUIRED EVERY 200'. THE MINIMUM WIDTH OF THE WALKWAY IS 48".

COVER OR DEACTIVATE ANY PEDESTRIAN TRAFFIC SIGNALS CONTROLLING CLOSED CROSSWALKS.

POST-MOUNTED SIGNS LOCATED ADJACENT TO A SIDEWALK SHALL HAVE A 7' MINIMUM CLEARANCE FROM THE BOTTOM OF THE LOWEST SIGN TO THE SIDEWALK SURFACE. SHARED-USE PATH SHALL HAVE 8' MINIMUM CLEARANCE FROM THE BOTTOM OF THE LOWEST SIGN TO THE SHARED USE PATH SURFACE.

APR SHOULD BE KEPT FREE OF TRASH, SEDIMENT, AND DEBRIS.

ANY PORTABLE SIGN OR BARRICADE PLACED OR STORED IN A PEDESTRIAN WALKWAY THAT COULD POSE A HAZARD TO A VISUALLY-IMPAIRED PEDESTRIAN SHALL HAVE A DETECTABLE EDGE TO GUIDE THE PEDESTRIAN AROUND THE HAZARD. FOR ADDITIONAL GUIDANCE, SEE THE "DETECTABLE EDGE FOR SIGN ON PORTABLE STAND" DETAIL ON STANDARD PLAN 5-297.813.

MINIMIZE DISRUPTION TO PEDESTRIANS TO THE MAXIMUM EXTENT FEASIBLE BY PROVIDING AN APR IN THE FOLLOWING ORDER OF PREFERENCE:

1. BYPASSES.
 - WHERE NOT FEASIBLE TO PROVIDE A SAME-SIDE APR, PROVIDE AN APR DETOUR ON THE OTHER SIDE OF THE ROADWAY.
 - WHERE NOT FEASIBLE TO PROVIDE AN APR ON EITHER SIDE OF THE ROADWAY, PROVIDE AN APR DETOUR WITH TRAILBLAZING SIGNS.
2. RECOMMENDED TAPER WHEN THE CLOSED AREA WAS PREVIOUSLY USED AS AN INTERMITTENT TRAFFIC LANE OR BYPASS LANE IS 25' LONG USING FIVE EQUALLY-SPACED CHANNELIZING DEVICES.
3. FOR FULLY-ACCESSIBLE WALKWAYS THROUGH WORKZONES, CONSIDER DISPLAYING THE INTERNATIONAL SYMBOL OF ACCESSIBILITY.
4. INCLUDE INFORMATION SUCH AS THE DURATION OF THE WALKWAY RESTRICTIONS (BEGINNING AND/OR END DATES) AND A PROJECT CONTACT NUMBER FOR 24/7 QUESTIONS OR REPORTING HAZARDS ON SIGNS FOR TEMPORARY PEDESTRIAN DETOURS.
5. SEE THE MOST CURRENT EDITION OF THE MNDOT TEMPORARY BARRIER GUIDANCE MANUAL FOR GUIDANCE ON PLACEMENT AND USAGE OF TEMPORARY BARRIER.

6. PROVIDE SOIL STABILIZATION AROUND TEMPORARY SURFACES TO PREVENT EROSION, IF NEEDED.

LEGEND

- + SIGN
- [Hatched Box] WORK AREA
- [Dashed Line] PEDESTRIAN CHANNELIZATION DEVICE
- [Solid Line] TEMPORARY BARRIER
- [Arrow] DIRECTION OF TRAFFIC
- [Dot] CHANNELIZER
- [Speaker Icon] AUDIBLE MESSAGE DEVICE (AMD)
- [Cross-hatched Box] TEMPORARY CURB RAMP WITH DETECTABLE EDGES
- [X-hatched Box] TEMPORARY WALKWAY SURFACE

REVISION:
 APPROVED: 03-18-2021
 BRIAN SOBERSON
 STATE TRAFFIC ENGINEER

m MINNESOTA DEPARTMENT OF TRANSPORTATION
 STANDARD PLAN 5-297.811 1 OF 2
 APPROVED: 03-18-2021
 THOMAS STYRBICKI
 STATE DESIGN ENGINEER

ALTERNATE PEDESTRIAN ROUTE (APR) LAYOUTS
 STATE PROJ. NO. (TH) SHEET NO. OF SHEETS

DISTRICT #: Metro
 PLOT NAME: APR - TPAR Sample Plan 3 for reference only
 PATH & FILENAME: O:\T\WorkZone\Templates\2020\new 20191230 APAR\APR-TPAR Sample Plan 20210602\APR - TPAR Sample Plan 3 for reference only.dgn
 PLOTTED/REVISED: 4-NOV-2021

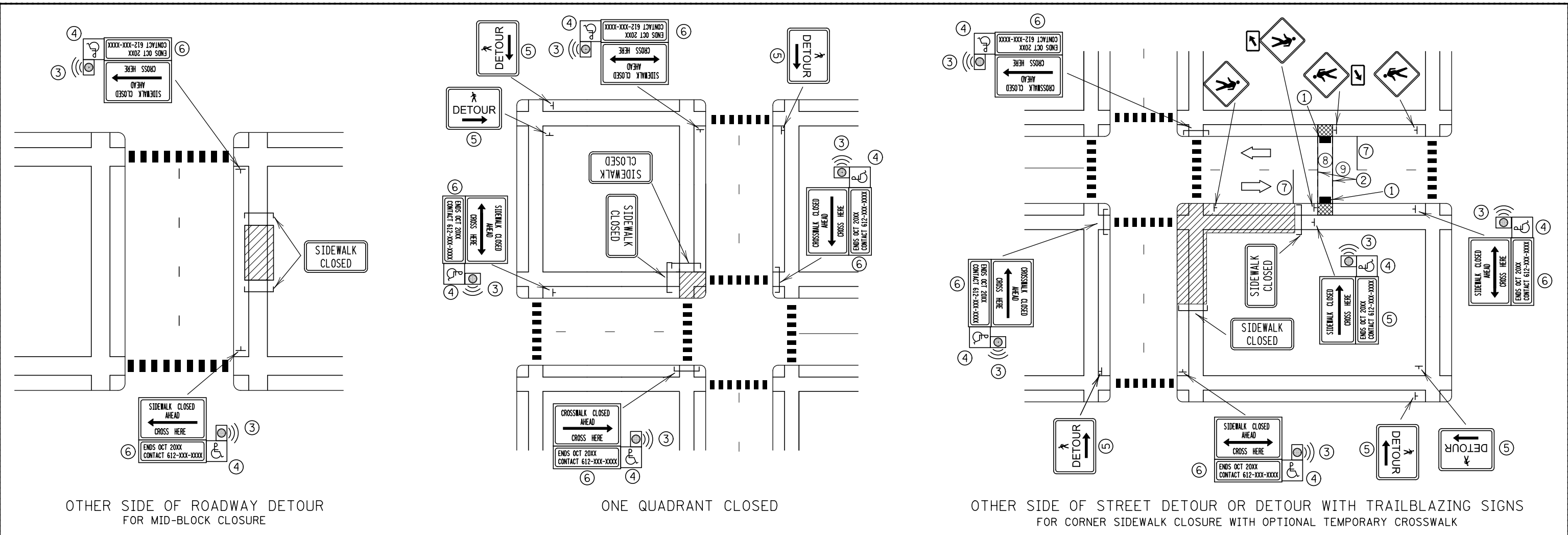

NOTES:

WHEN CLOSING OR RELOCATING CROSSWALKS OR SIDEWALKS, PROVIDE DETECTABLE TEMPORARY FACILITIES AND INCLUDE ACCESSIBILITY FEATURES CONSISTENT WITH EXISTING PEDESTRIAN FACILITIES. THE MINIMUM TEMPORARY WALKWAY WIDTH SHOULD BE THE WIDTH OF THE EXISTING FACILITY. IF THE EXISTING FACILITY HAS A WIDTH GREATER THAN 60", THE WIDTH OF THE TEMPORARY FACILITY MAY BE 60". IF THE WIDTH OF THE DETOUR IS LESS THAN 60", A 60"-WIDE PASSING SPACE IS REQUIRED EVERY 200'.

TEMPORARY TRAFFIC CONTROL DEVICES FOR PEDESTRIANS ARE SHOWN. OTHER TRAILBLAZING SIGNS OR DEVICES MAY BE NEEDED FOR ADEQUATE ROUTING. STAGE WORK AS NECESSARY TO PROVIDE AN ALTERNATE PEDESTRIAN ROUTE (APR) AT ALL TIMES.

PROVIDE A SMOOTH, CONTINUOUS, HARD SURFACE THROUGH THE LENGTH OF THE APR. PROVIDE A FIRM, STABLE, FREE-DRAINING, NON-SLIP, TEMPORARY WALKWAY SURFACE REGARDLESS OF WEATHER CONDITIONS. SUPPORT THE TEMPORARY WALKWAY SURFACE WITH A SOLID BASE TO COVER SHORT SEGMENTS OF ROUGH, SOFT, OR UNEVEN GROUND. THE TEMPORARY WALKWAY SURFACE WILL ALLOW NORMAL USAGE OF WHEELCHAIRS, WALKERS, STROLLERS, AND OTHER MOBILITY DEVICES. CONCRETE, BITUMINOUS, STEEL, RUBBER, WOOD (3/4" OR THICKER), AND PLASTIC ARE ACCEPTABLE SURFACE MATERIALS FOR THE TEMPORARY WALKWAY SURFACE. GRAVEL, MILLINGS, OR OTHER UNEVEN SURFACES ARE NOT ACCEPTABLE SURFACE MATERIALS. IF NEEDED, PROVIDE SOIL STABILIZATION TO PREVENT EROSION AROUND TEMPORARY SURFACES.

COVER OR DEACTIVATE ANY PEDESTRIAN TRAFFIC SIGNALS CONTROLLING CLOSED CROSSWALKS.

APR SHOULD BE KEPT FREE OF TRASH, SEDIMENT, AND DEBRIS.

POST-MOUNTED SIGNS ADJACENT TO SIDEWALKS SHALL HAVE 7' MINIMUM CLEARANCE FROM THE BOTTOM OF THE LOWEST SIGN TO THE SIDEWALK SURFACE. SHARED-USE PATHS SHALL HAVE 8' MINIMUM CLEARANCE FROM THE BOTTOM OF THE LOWEST SIGN TO THE SHARED-USE PATH SURFACE.

ANY PORTABLE SIGN OR BARRICADE PLACED OR STORED IN A PEDESTRIAN WALKWAY THAT COULD BE A HAZARD TO A VISUALLY-IMPAIRED PEDESTRIAN SHALL HAVE A DETECTABLE EDGE TO GUIDE THE PEDESTRIAN AROUND THE HAZARD. FOR ADDITIONAL GUIDANCE SEE THE "TEMPORARY PEDESTRIAN ACCESS ROUTE (TPAR) DEVICES" STANDARD PLAN, "DETECTABLE EDGE FOR SIGN ON PORTABLE STAND" DETAIL.

MINIMIZE DISRUPTION TO PEDESTRIANS TO THE MAXIMUM EXTENT FEASIBLE BY PROVIDING AN APR IN THE FOLLOWING ORDER OF PREFERENCE:

1. PROVIDE THE APR ON THE SAME SIDE OF THE ROADWAY AS THE DISRUPTED ROUTE UTILIZING BYPASSES.
2. WHERE IT IS NOT FEASIBLE TO PROVIDE A SAME-SIDE APR, PROVIDE AN APR DETOUR ON THE OTHER SIDE OF THE ROADWAY.
3. WHERE IT IS NOT FEASIBLE TO PROVIDE AN APR ON EITHER SIDE OF THE ROADWAY, PROVIDE AN APR DETOUR WITH TRAILBLAZING SIGNS.

- ① TEMPORARY CURB RAMP WITH DETECTABLE WARNINGS.
- ② TEMPORARY PAVEMENT MARKINGS FOR CROSSWALKS MAY USE CROSSWALK BLOCKS, TWO TRANSVERSE LINES OR TWO STRIPS OF 18" PREFORMED MARKING MATERIAL TO FORM 36" WIDE CROSSWALK BLOCKS.
- ③ PROVIDE AN APPROVED AUDIBLE MESSAGE DEVICE OR TACTILE MESSAGE FOR PEDESTRIANS WITH VISUAL DISABILITIES.

- ④ FOR FULLY ACCESSIBLE WALKWAYS THROUGH WORKZONES, CONSIDER DISPLAYING THE INTERNATIONAL SYMBOL OF ACCESSIBILITY.
- ⑤ USE PEDESTRIAN DETOUR TRAILBLAZING SIGNS IF THE PEDESTRIAN DETOUR IS NOT LOCATED ACROSS THE ROADWAY FROM THE SIDEWALK CLOSURE.
- ⑥ TYPICAL SIGN MESSAGE FOR AN ALTERNATE PEDESTRIAN ROUTE SHOULD INCLUDE INFORMATION SUCH AS THE DURATION OF THE WALKWAY RESTRICTIONS (BEGINNING AND/OR END DATES) AND A PROJECT CONTACT NUMBER FOR 24/7 QUESTIONS OR REPORTING HAZARDS. TYPICAL INFORMATION INCLUDED IN AN AUDIBLE MESSAGE CAN BE FOUND IN "TPAR - AUDIBLE MESSAGE CONTENT GUIDELINES" AVAILABLE ON THE MNDOT TRAFFIC ENGINEERING WEBSITE ON THE PEDESTRIAN ACCOMMODATIONS THROUGH WORK ZONES WEB PAGE. ADDITIONALLY, A SUMMARY OF THE MESSAGE CONTENT GUIDELINES CAN BE FOUND WITHIN THE PEDESTRIAN ACCOMMODATIONS THROUGH WORK ZONES DESIGN GUIDANCE DOCUMENT.
- ⑦ LOCATE STOP BAR 20' TO 50' BEFORE THE CROSSWALK. RESTRICT PARKING BETWEEN THE STOP BAR AND THE CROSSWALK. ON TWO-WAY ROADWAYS, RESTRICT PARKING BOTH BEFORE AND AFTER THE CROSSWALK FOR BOTH DIRECTIONS.
- ⑧ CONSIDER LIGHTING AT MID-BLOCK CROSSINGS IN ORDER TO ILLUMINATE PEDESTRIANS, IF NOT ALREADY LIT.
- ⑨ CONSIDER THE ADDITION OF R1-6a SIGNS AS MOTORISTS ARE NOT EXPECTING MID-BLOCK CROSSING.

LEGEND

- SIGN
- DIRECTION OF TRAFFIC
- ▨ WORK AREA
- Ⓜ AUDIBLE MESSAGE DEVICE (AMD)
- ▩ TEMPORARY CURB RAMP WITH DETECTABLE EDGES

R1-6a

REVISION:

APPROVED: 03-18-2021

Brian Sobenson
 BRIAN SOBENSON
 STATE TRAFFIC ENGINEER

m MINNESOTA
 DEPARTMENT OF TRANSPORTATION

STANDARD PLAN 5-297.811 **2 OF 2**

APPROVED: 03-18-2021
 REVISED:

Tom Styrbicki
 THOMAS STYRBICKI
 STATE DESIGN ENGINEER

STATE PROJ. NO. (TH) SHEET NO. OF SHEETS

ALTERNATE PEDESTRIAN ROUTE (APR) LAYOUTS

DISTRICT #: Metro
 PLOT NAME: APR - TPAR Sample Plan 3 for reference only
 PATH & FILENAME: OTST\WorkZone\Templates\2020\new 20191230 APAR\APP-TPAR Sample Plan 20210602\APR - TPAR Sample Plan 3 for reference only.dgn
 PLOTTED/REVISED: 4-NOV-2021

NOTES;

- TPAR SHOULD BE KEPT FREE OF TRASH, SEDIMENT, AND DEBRIS.
- RAILINGS OR OTHER OBJECTS MAY PROTRUDE A MAXIMUM OF 4" INTO THE WALKWAY CLEAR SPACE WHEN LOCATED A MINIMUM OF 27" ABOVE THE WALKWAY SURFACE.
- USE CRASHWORTHY TEMPORARY BARRIERS WHEN USED AS A PEDESTRIAN CHANNELIZERS.
- PLACE SIDEWALK BARRICADES ACROSS THE ENTIRE WIDTH OF THE WALKWAYSURFACE, WHEN USED.
- USE INTERLOCKING DEVICES TO CHANNELIZE PEDESTRIAN FLOW TO PREVENT GAPS THAT COULD ALLOW PEDESTRIANS TO STRAY FROM THE CHANNELIZED PATH.
- ① PROVIDE DETECTABLE EDGE TO ANY TRIPPING HAZARD IN THE WALKWAY. LOCATE BALLAST BEHIND THE DETECTABLE EDGE OR INTEGRAL TO THE DEVICE. ANY SUPPORT ON THE FRONT OF THE DEVICE SHOULD NOT EXTEND INTO THE 48" MINIMUM WALKWAY CLEAR SPACE. ANY SUPPORT THAT EXTENDS INTO THE WALKWAY SHALL NOT EXCEED 1/2" HEIGHT ABOVE THE WALKWAY SURFACE; IF GREATER THAN 1/4", BEVEL AS SHOWN IN THE TRIP HAZARD DETAIL.
- ② PROVIDE CONTINUOUS DETECTABLE EDGES EXTENDING AT LEAST 6" ABOVE THE WALKWAY SURFACE. MARK DETECTABLE EDGES WITH A COLOR THAT CONTRASTS WITH THE WALKWAY SURFACE. PLACE THE DETECTABLE EDGE AROUND ANY PORTABLE SIGN STAND IN THE WALKWAY AREA WHERE THE SIGN POSES A HAZARD TO A VISUALLY-IMPAIRED PEDESTRIAN.
- ③ DEVICES AND DETECTABLE EDGES SHALL NOT BLOCK WATER DRAINAGE FROM THE WALKWAY. A GAP HEIGHT OR OPENING FROM THE WALKWAY SURFACE UP TO A MAXIMUM OF 2" IS ALLOWED FOR DRAINAGE PURPOSES.
- ④ USE HAND AND GUIDE RAILS WHEN REQUIRED. INSTALL TOP RAIL OR TOP SURFACE IN A VERTICAL PLANE PERPENDICULAR TO THE WALKWAY, ABOVE THE DETECTABLE EDGE. PROVIDE CONTINUOUS RAIL AT A HEIGHT OF 34" TO 38" ABOVE THE WALKWAY SURFACE. USE RAIL SUPPORTS THAT MINIMIZE CONTACT WITH PEDESTRIAN'S HANDS AND FINGERS. SEE "PUBLIC RIGHTS OF WAY ACCESSIBILITY GUIDELINES (PROWAG) 2005" FOR ADDITIONAL GUIDANCE ON USE OF HAND AND GUIDE RAILS.
- ⑤ USE DEVICES FREE OF SHARP OR ROUGH EDGES, AND USE ROUNDED FASTENERS (BOLTS) TO PREVENT HARM TO A PEDESTRIAN'S HANDS, ARMS, AND CLOTHING.
- ⑥ REGARDLESS OF WEATHER CONDITIONS PROVIDE FIRM, STABLE, FREE-DRAINING, AND NON-SLIP TEMPORARY WALKWAY SURFACES. TEMPORARY WALKWAY SURFACES SHALL ALLOW NORMAL USAGE OF WHEELCHAIRS, WALKERS, STROLLERS, OR OTHER MOBILITY DEVICES. CONCRETE, BITUMINOUS, STEEL, RUBBER, WOOD (3/4" OR THICKER), AND PLASTIC ARE ACCEPTABLE SURFACE MATERIALS FOR A TEMPORARY WALKWAY SURFACE. GRAVEL, MILLINGS, AND OTHER UNEVEN SURFACES ARE NOT ACCEPTABLE SURFACE MATERIALS.
- ⑦ PROVIDE 32" HIGH OR GREATER LONGITUDINAL CHANNELIZING DEVICES FOR PEDESTRIANS.
- ⑧ AN EDGE OF THE FRAMING MAY BE REMOVED IF IT IS NOT NEEDED FOR PEDESTRIAN GUIDANCE. STABILITY OF THE DETECTABLE EDGE SHOULD BE MAINTAINED.
- ⑨ TYPICAL. SEE SIGNING PLAN FOR DETAILS.

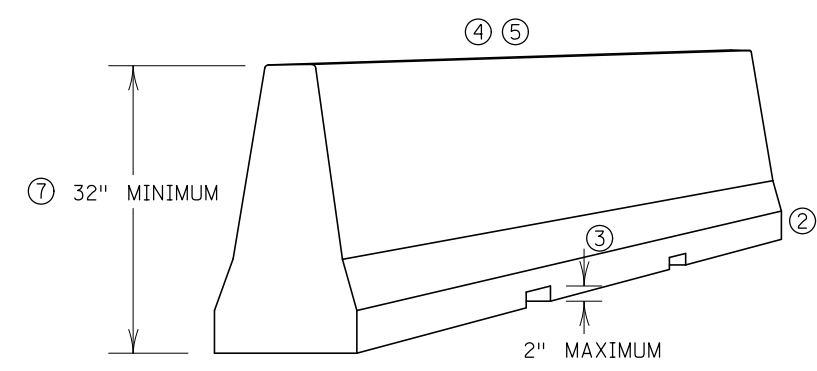
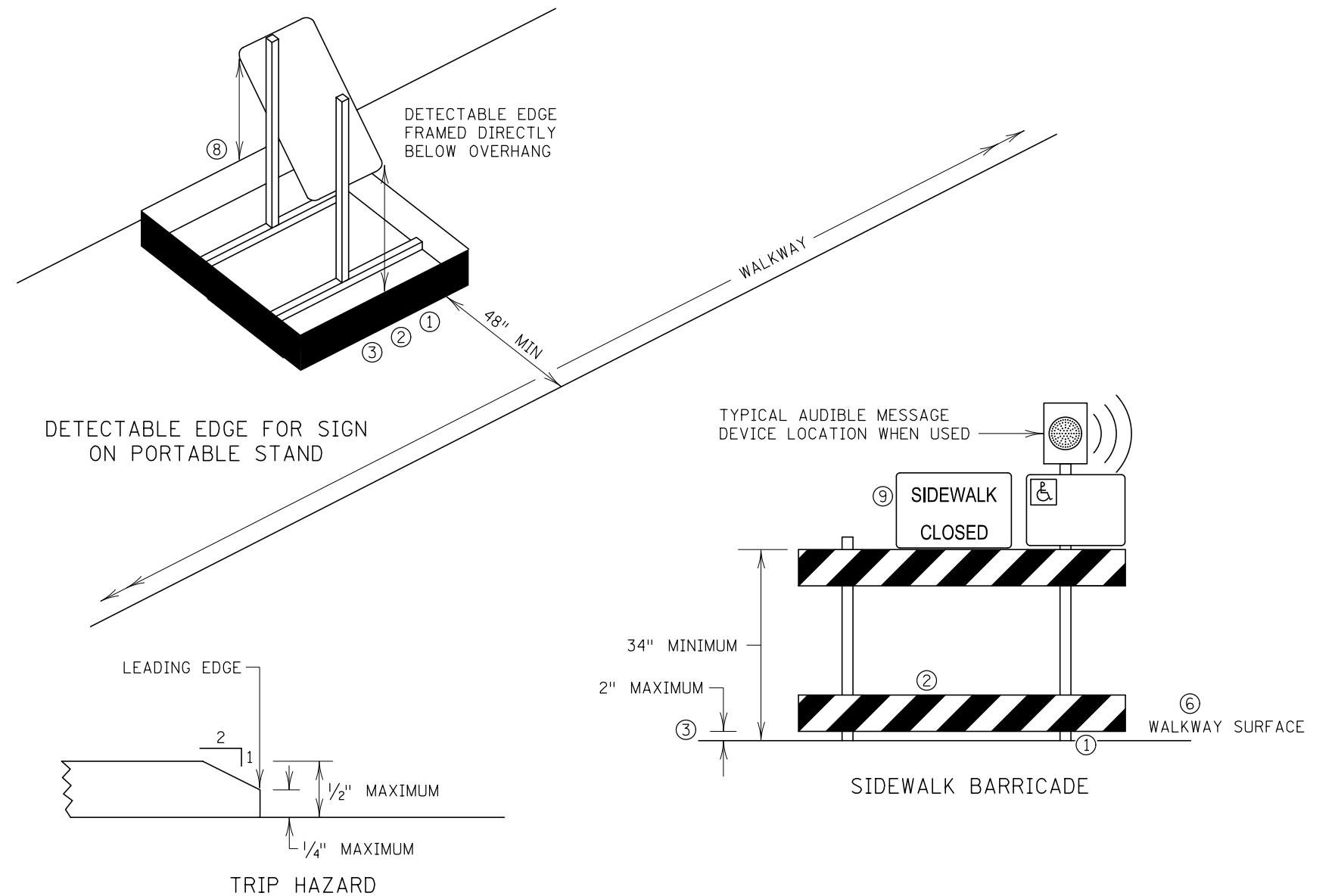

PEDESTRIAN CHANNELIZER DEVICE USING A PORTABLE CONCRETE BARRIER

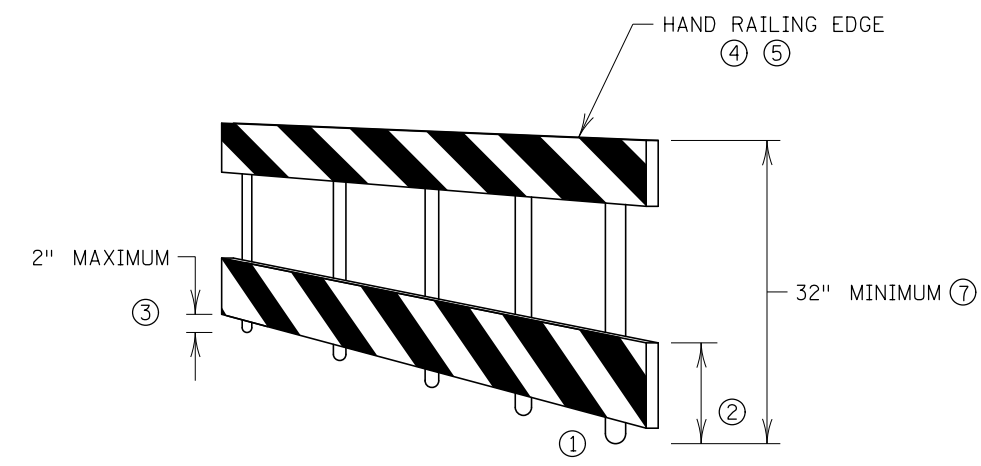

PEDESTRIAN CHANNELIZER

REVISION:
APPROVED: 03-18-2021
<i>Brian Sobenson</i> BRIAN SOBENSON STATE TRAFFIC ENGINEER

	STANDARD PLAN 5-297.813	1 OF 2	TEMPORARY PEDESTRIAN ACCESS ROUTE (TPAR) DEVICES CHANNELIZERS, SIDEWALK BARRICADES, AND PORTABLE STANDS		
	 THOMAS STYRBICKI STATE DESIGN ENGINEER	APPROVED: 03-18-2021			

DISTRICT #: Metro
 PLOT NAME: APR - TPAR Sample Plan 3 for reference only
 PATH & FILENAME: O:\ST\WorkZone\Templates\2020\new 20191230 APAR\APP-TPAR Sample Plan 20210602\APR - TPAR Sample Plan 3 for reference only.dgn

NOTES:

CONSTRUCT SLOPES AS INDICATED OR FLATTER, BUT NOT STEEPER.
 TPAR SHOULD BE KEPT FREE OF TRASH, SEDIMENT, AND DEBRIS.

- ① CONSTRUCT CURB RAMPS AT LEAST 48" WIDE WITH A FIRM, STABLE, AND SLIP-RESISTANT SURFACE.
- ② PLACE PROTECTIVE EDGING WITH A 2" MINIMUM HEIGHT WHEN A CURB RAMP OR LANDING PLATFORM HAS A VERTICAL DROP OF 6" OR GREATER OR HAS A SIDE APRON SLOPE STEEPER THAN 1V:3H. CONSIDER PROTECTIVE EDGING WHEN CURB RAMPS OR LANDING PLATFORMS HAVE A VERTICAL DROP OF 3" OR MORE.
- ③ PLACE DETECTABLE EDGING WITH 6" MINIMUM HEIGHT AND CONTRASTING COLOR ON ALL CURB RAMP LANDINGS WHERE THE WALKWAY CHANGES DIRECTION.
- ④ CONSTRUCT CURB RAMPS AND LANDINGS WITH A 2% OR FLATTER CROSS SLOPE.
- ⑤ PROVIDE A CLEAR SPACE OF AT LEAST 48" X 48" ABOVE AND BELOW THE CURB RAMP.
- ⑥ MARK THE CURB RAMP WALKWAY EDGE WITH A 2" TO 4" WIDE MARKING OF CONTRASTING COLOR. THE MARKING IS OPTIONAL WHERE COLOR-CONTRASTING EDGING IS USED.
- ⑦ DO NOT IMPEDE WATER FLOW IN THE GUTTER SYSTEM.
- ⑧ NO LATERAL JOINTS OR GAPS BETWEEN SURFACES SHALL EXCEED 1/2" WIDTH.
- ⑨ CHANGES BETWEEN SURFACE HEIGHTS SHALL NOT EXCEED 1/2". USE VERTICAL LATERAL EDGES UP TO 1/4" HIGH, AND BEVELED AT 1V:2H FOR LATERAL EDGES BETWEEN 1/4" AND 1/2" HEIGHT.
- ⑩ BEVEL THE EDGE OF TEMPORARY WALKWAY SURFACES 1/2" OR THINNER AT 1V:2H. FOR THICKER WALKWAY SURFACE BEVEL EDGE 1V:20H OR FLATTER.

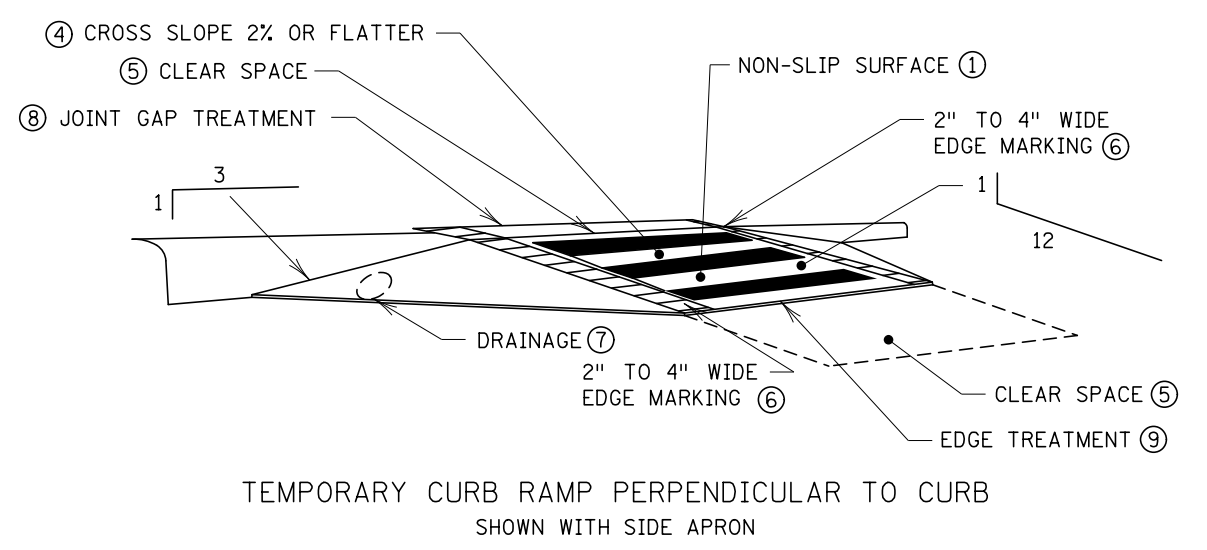
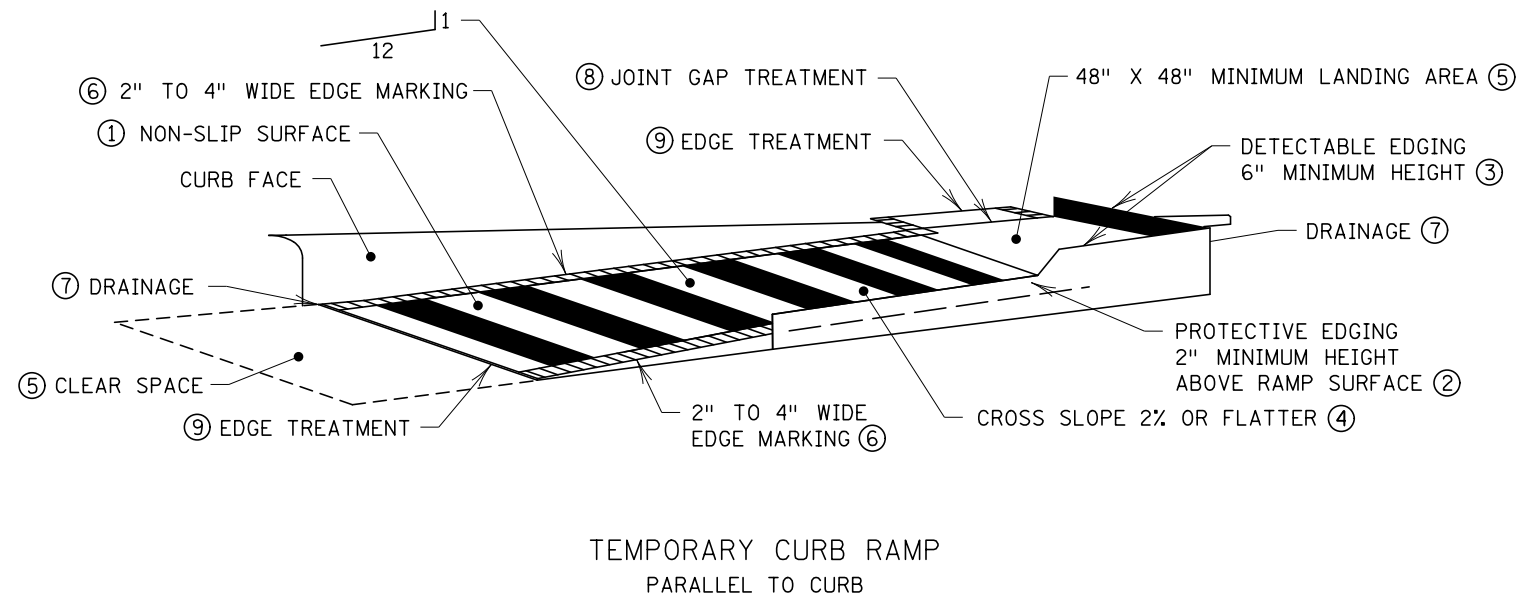
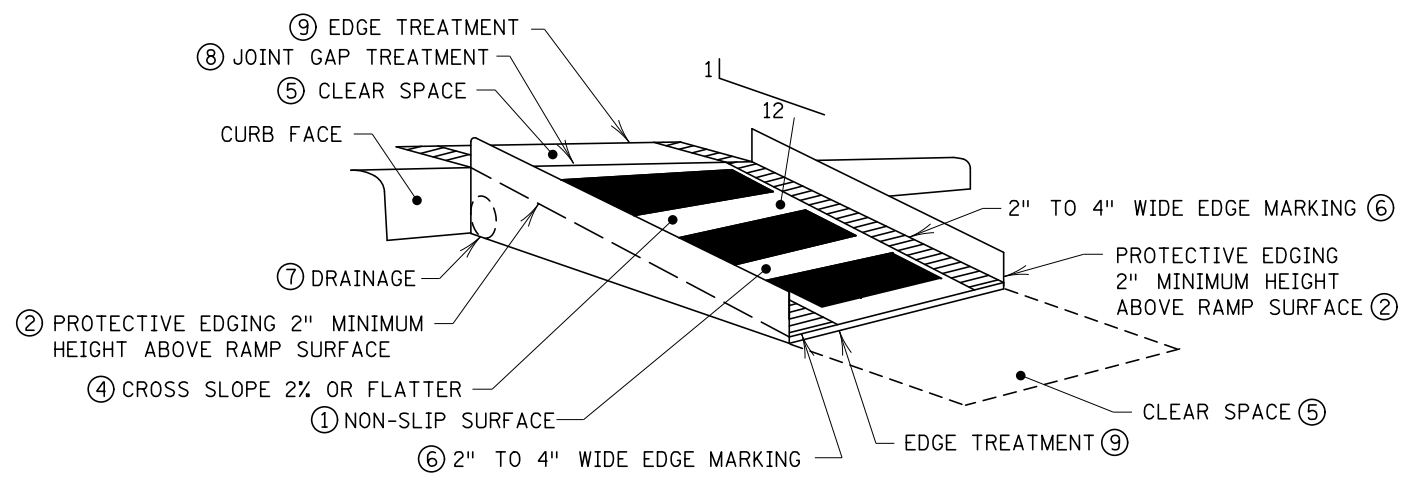
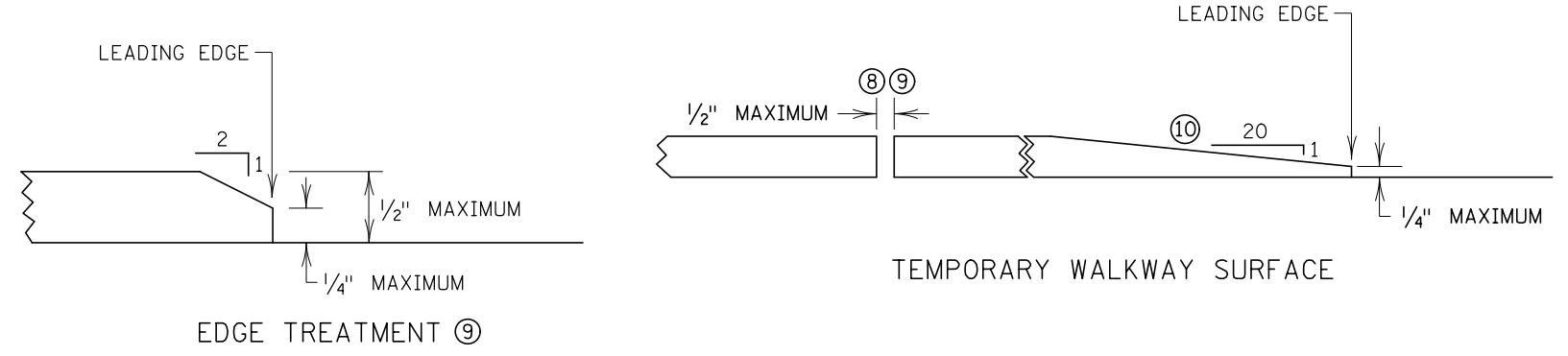

REVISION:
APPROVED: 03-18-2021 BRIAN SOBENSON STATE TRAFFIC ENGINEER

 DEPARTMENT OF TRANSPORTATION	STANDARD PLAN 5-297.813	2 OF 2	TEMPORARY PEDESTRIAN ACCESS ROUTE (TPAR) DEVICES TEMPORARY CURB RAMPS AND WALKWAY SURFACES	
	 THOMAS STYRBICKI STATE DESIGN ENGINEER	APPROVED: 03-18-2021 REVISED:		